

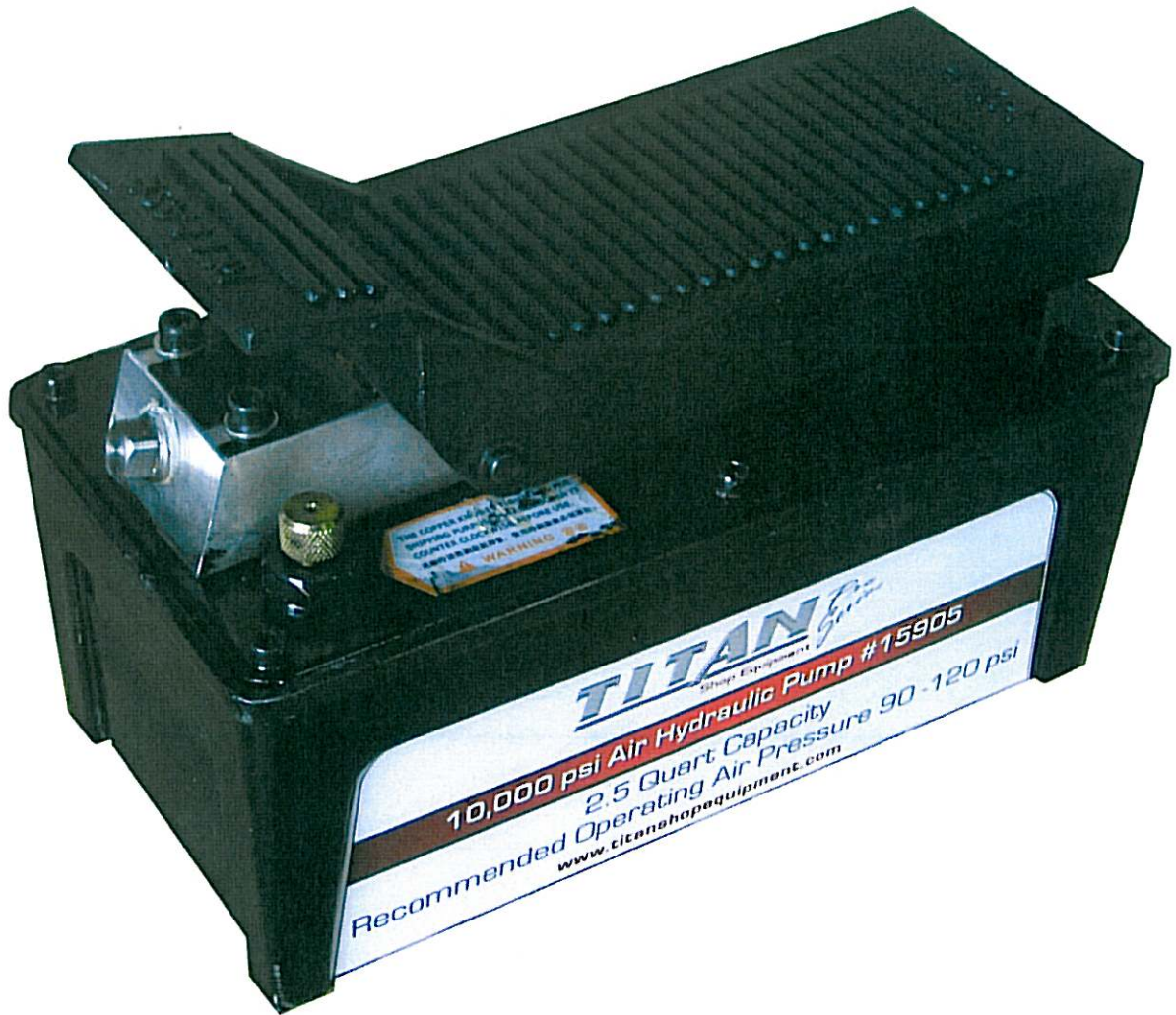

15905 Instruction Manual & Parts List

2.5 Qt. Air Pump w/ Aluminum Reservoir



Model 15905

**ALUMINUM RESERVIOR
10,000 PSI, AIR-HYDRAULIC PUMP**

AME International
2324 Circuit Way
Brooksville, FL 34604
(877)775-4263
www.ameintl.net

SPECIFICATION

Input Air Pressure (psi)	Input Port Threads	Output Port Threads	Oil Delivery (cu.in./min)		Internal Relief Setting (Psi)	Usable Oil Capacity (cu.in.)	Weight (lbs. w/fluid)	L+W+H
			0 psi	10,000 psi				
90-140	¼-18 NPT	3/8-18 NPT	24.4	7.3	10,000	140	19	12.3"x6.7"x7.5"

DESCRIPTION

This Air/Hydraulic Pump supplies hydraulic fluid pressure to selected tools. It consists of an in-line air and hydraulic cylinder. The ratio of hydraulic fluid pressure generated compared to supply air pressure is 100:1. In other words, 100 PSI out of every 1 PSI in – 100 PSI input air pressure equals 10,000 PSI output pressure.

Depressing the **RELEASE** pedal causes a decrease in pressure and pressing the **PUMP** end of the pedal provides fluid pressure.

WARNING

The air hydraulic is capable of generating fluid pressure up to 10,000 psi. Make certain the tool in use is held securely and is in proper working condition. Do not continue to operate the pump once the work is completed. Failure to comply with these instructions could result in personal injury or damage to the equipment.

BEFORE USE

To prevent oil leak during shipment, a metal knob is installed and tightened to ensure the best sealing function. Loosen it counterclockwise before use.

Note: Always secure threaded port connections with non-hardening pipe thread compound. Tighten securely to prevent accidental removal of components while in use. Take care not to introduce compound into port orifices. Familiarize yourself with the specifications and illustrations in this operator's manual. Know your pump, its limitations and how it operates before attempting o use. Refer to specification chart on above for details of oil port thread size, usable oil capacity, and more.

OPERATION

Operation of the unit is as follows:

1. Connect the hose of the Air/Hydraulic Pump to the hydraulic coupling on the selected tool.
2. Connect the air supply line to the Air/Hydraulic Pimp. Air supply should be 5-10 CFM at 100 PSI to obtain proper operating characteristics. In addition, the air line should be equipped with an air line filter
3. Stepping on the **PUMP** end of the pedal engager the pump, producing the force necessary to run the tool.
4. Depressing the **RELEASE** end of the pump pedal will release the pressure.

MAINTENANCE

1. Inspect hoses and connections daily.
2. Tighten connections as needed. Use non-hardening pipe thread compound when servicing connections.
3. Use only good quality hydraulic fluid. We recommend Mobil DTE13M or equivalent.

When not in use or during storage:

- a. Depressurize and disconnect hydraulic hoses from application.
- b. Wipe clean, thoroughly.
- c. Store in clean, dry environment. Avoid temperature extremes.
- d. Shield pump with a protective cover.

Adding Hydraulic Fluid

1. Depressurize and disconnect hydraulic hose from application.
2. With pump in its upright, horizontal position, remove the oil filter plug located on the top plate of reservoir.
3. Use a small funnel to fill reservoir to within $\frac{3}{4}$ "(19mm) of the opening

Note: Use only good quality hydraulic jack oil

Never use brake fluid, transmission fluid, turbine oil, motor oil, alcohol, glycerin etc. Use of other than good quality hydraulic oil will void warranty and damage the pump, hose and application.

4. Wipe up any spilled fluid and reinstall the oil filter plug.

Changing Hydraulic Fluid

1. For best results, change fluid once a year.
2. Repeat #2 above, then pour used fluid into a sealable container.
3. Dispose of fluid in accordance with local regulations
4. Fill with good quality hydraulic jack oil as recommended above. Reinstall vented oil filter plug.

Lubrication

Use a light machine oil to lubricate pivot points, hinges etc.

Note: Never operate pump with release valve closed and disconnected from application. If operated in this condition, the hose and connections become pressurized. This increases burst hazard. Damage may occur to pump and its components.

Parts List of Air Hydraulic Pump

Item No	Part No	Description	Qty	Item No	Part No	Description	Qty	Item No	Part No	Description	Qty
1	15905-001	Oil reservoir	1	31	15905-031	Rear Cover	1	61	15905-061	Screw	12
2	15905-002	Oil Filter	1	32	15905-032	O-Ring	1	62	15905-062	O-Ring	2
3	15905-003	Oil Filter	1	33	15905-033	O-Ring	1	63	15905-063	Oil Filter Plug	1
4	15905-004	Valve Block	1	34	15905-034	Bolt	1	64	15905-064	Oil Filter Plug	1
5	15905-005	Screw	1	35	15905-035	Fixing Base	1	65	15905-065	Screw	1
6	15905-006	Spring	1	36	15905-036	O-Ring	2	66	15905-066	Oil Filter	1
7	15905-007	Ball Seat	1	37	15905-037	O-Ring	1	67	15905-067	O-Ring	1
8	15905-008	Steel Ball	1	38	15905-038	O-Ring	1	68	15905-068	O-Ring	1
9	15905-009	Safety Valve	1	39	15905-039	Spring	1	69	15905-069	Exhaust Muffler	1
10	15905-010	Bolt	8	40	15905-040	Ball Seat	1	70	15905-070	Fixing Base	1
11	15905-011	CopperWasher	1	41	15905-041	Steel Ball	1	71	15905-071	Bolt	4
12	15905-012	Pump Cylinder	1	42	15905-042	O-Ring`	1	72	15905-072	Spring	1
13	15905-013	Y-Seal	1	43	15905-043	NylonGasket	1	73	15905-073	Snap Ring	2
14	15905-014	NylonGasket	1	44	15905-044	ReleaseValve	1	74	15905-074	Shaft	1
15	15905-015	CopperWasher	1	45	15905-045	Ball Seat	1	75	15905-075	Foot Pedal	1
16	15905-016	Nut	1	46	15905-046	Spring	1	76	15905-076	O-Ring	1
17	15905-017	Spring	1	47	15905-047	O-Ring	1	77	15905-077	Screw	1
18	15905-018	O-Ring	1	48	15905-048	Release Rod	1	78	15905-078	Air Valve	1
19	15905-019	Pump Housing	1	49	15905-049	O-Ring	4	79	15905-079	Spring	1
20	15905-020	Washer	1	50	15905-050	Steel Ball	1	80	15905-080	Seal	1
21	15905-021	Pump Plunger	1	51	15905-051	Spring	1	81	15905-081	Bolt	2
22	15905-022	Air PistonBase	1	52	15905-052	Steel Ball	1	82	15905-082	Air Valve Rod	1
23	15905-023	O-Ring	2	53	15905-053	Spring	1	83	15905-083	O-Ring	1
24	15905-024	AirValve Shuttle	1	54	15905-054	O-Ring	1	84	15925-084	O-Ring	1
25	15905-024	O-Ring	2	55	15905-055	NylonGasket	1	84	15905-085	Seitch Coupler	1
26	15905-026	Piston	1	56	15905-056	Coupler	1				
27	15905-027	Bolt	3	57	15905-057	NylonGasket					
28	15905-028	ShuttleValve Seal	1	58	15905-058	O-Ring	1				
29	15905-029	O-Ring	2	59	15905-059	Seal					
30	15905-030	O-Ring	1	60	15905-060	Cover					

Parts Breakdown Diagram

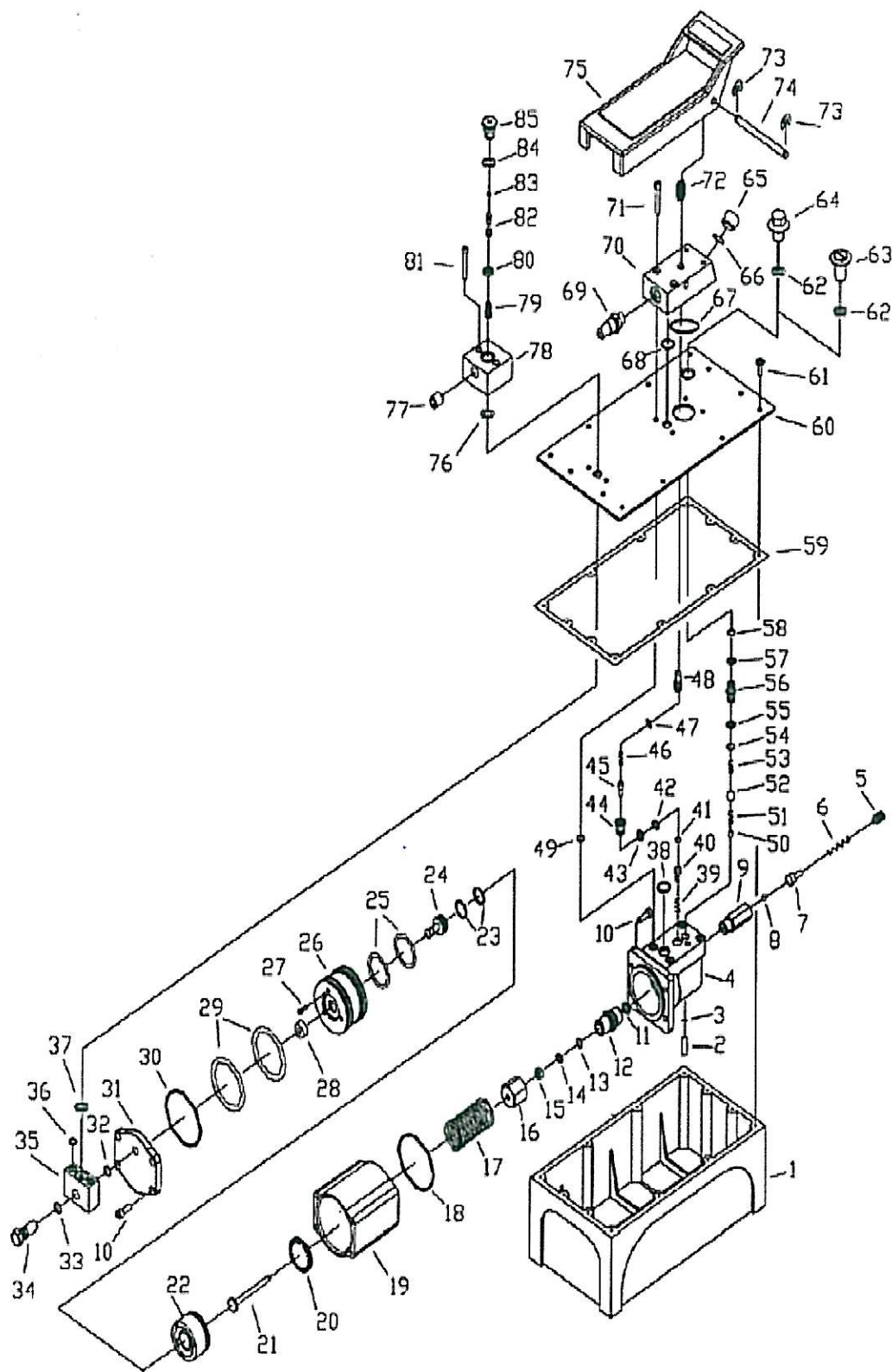

Symptom	Possible Causes	Corrective Action
Application will not extend, move or respond to pressurized fluid	<ul style="list-style-type: none"> • Overload Condition • Release Valve not closed 	<ul style="list-style-type: none"> • Remedy overload Condition • Ensure release valve closed
Application responds to pressurized fluid, but system does not maintain pressure	<ul style="list-style-type: none"> • Overload Condition • Release Valve not closed • Hydraulic unit malfunction 	<ul style="list-style-type: none"> • Remedy overload Condition • Ensure release valve closed
Application will not return fluid to pump (ie. Cylinder will not retract)	<ul style="list-style-type: none"> • Malfunctioning coupler, damaged application • Reservoir overfilled 	<ul style="list-style-type: none"> • Secure load by other means. Open release valve, depressurize pump and hose, remove coupler and/or application, then renew or replace • Secure load by other means. Open release valve, depressurize pump and hose, remove application, then drain fluid to proper level
Application will not fully extend (cylinder or spreader)	<ul style="list-style-type: none"> • Fluid level low • Fluid level low 	<ul style="list-style-type: none"> • Follow Symptom 3 procedure for securing load, depressurizing pump, remove application, then ensure proper fluid level
Poor Performance	<ul style="list-style-type: none"> • Air trapped in System 	<ul style="list-style-type: none"> • Ensure proper fluid level • Ensure vented oil filler plug let pressurized reservoir air escape (see before use)



AME International
 2324 Circuit Way
 Brooksville, FL 34604
 (877)775-4263
www.ameintl.net